

Seed Conditioning & Processing Global Solution Partner



DE-STONER Pressure Type

Akyurek Technology manufactures two types of De-stoners:

Pressure-type with an enclosed deck and the fan placed inside the box creating a positive air pressure up through the vibrating deck with screen.

Vacuum-type which is completely enclosed with a fan mounted away from the machine, creating a "suction" of air through the vibrating deck with screen.

Akyurek Technology De-stoners are known for their remarkably fast and thorough separation of heavy foreign material removal, Right nw they are working throughout the world on spices, chemicals, coffee, peanut, cereals, beans, wheat, minerals and numerous other products.

The De-stoner operates on the basic principle of flowing dry granular material over a vibrating screen covered deck that is inclined. The Akyurek Technology De-stoners have the same basic function as gravity separator with the only difference being the De-stoner has two fractions - light & heavy, and the gravity separator has multiple fractions.

APPLICATION

De-stoners are placed in many different locations in a cleaning system, both before and after cleaners and gravity separators. Destoning is not only used as a means of eliminating contaminants to improve the purity of the product, but is also essential to remove stones to eliminate excessive wear on all types of grinding mills, flaking machines, etc.

Operation Mode

The basic principle involves flowing dry material over an inclined, vibrating, screen covered deck. The steady air flow holds the material in stratified flotation. The lighter material stays in the upper strata as it flows down the inclined vibrating deck with screens. The heavier material, such as stones, coarse sand, glass, metal, etc. travels up the inclined vibrating deck.

DE-STONER – Pressure Type

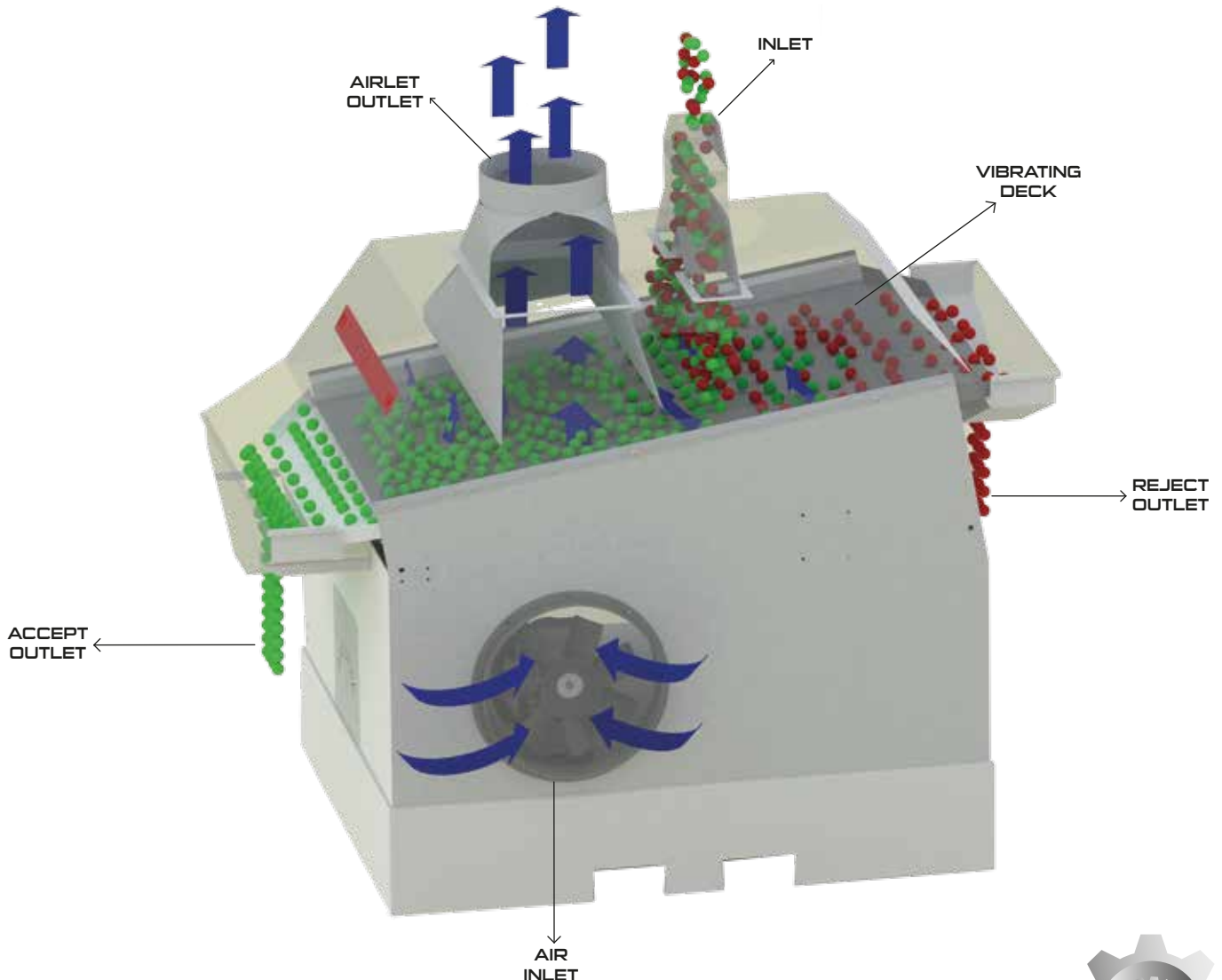

DE-STONER – Pressure Type Machine Range

		
Models T.MAC.009 MEDIUM MODEL	T.MAC.009 LARGE MODEL	T.MAC.009 XLARGE MODEL
Screen Area 0.92 m²	1.3 m²	2.5 m²

MOTORS	ADJUSTABLE PARAMETERS	TYPES		
		Mechanic TYPE	Semi Auto TYPE	PLC TYPE
Linear Vibrotary Feeder	Linear Feeding on Deck	Digital Potantimeter with Freq. Cont.	Digital Potantimeter with Freq. Cont.	PLC T/S PANEL with Frequency Controller
Eccentric fr Deck	Deck Speed	Fix Speed Eccentric - On and Off*	Fix Speed Eccentric - On and Off*	PLC T/S PANEL with Frequency Controller
Air Pressure Fan	Air Pressure	Manually Cont. Valves of Air inlet Gate*	Digital Potantimeter with Freq. Cont.	PLC T/S PANEL with Frequency Controller
Aspirator-Suction	Exhaust Suction	Manually Cont. Shutter from Aspirator	Manually Cont. Shutter from Aspirator	Manually Cont. Shutter from Aspirator
	Deck Rise and Low	Manual Controlled Jack Lift*	Manual Controlled Jack Lift*	MOTORISED PLC T/S PANEL
* Optionally: Frequency Controller can be used. Abriviations: T/S-Touch Screen Freq. Cont.- Frequency Controller				SETTINGS MEMORY SYSTEM for Re-Call CLEVER PERIODIC DISCHARGE SYSTEM

CAPACITY CHART

Product	m ³ / Kg	MEDIUM MODEL	LARGE MODEL	XLARGE MODEL
Soy Beans	700	3-5 tph	5-7 tph	7-9 tph
Chickpeas	740	3-5 tph	5-7 tph	8-10 tph
Beans	750	3-5 tph	5-7 tph	8-10 tph
Kidney	760	3-5 tph	5-7 tph	8-10 tph
Vetch	700	3-5 tph	5-7 tph	8-10 tph
Lentil	800	3-5 tph	5-7 tph	8-10 tph
Wheat	760	3-5 tph	5-7 tph	8-10 tph
Rice	750	3-5 tph	5-7 tph	8-10 tph
Sunflower	350	1-2 tph	2-3 tph	3-5 tph
Cumin	300	1.5-2 tph	2-3 tph	3-5 tph
Sesame	600	2-3 tph	3-4 tph	4-6 tph
Peas	700	3-5 tph	5-7 tph	8-10 tph
Bird Seed	700	3-5 tph	5-7 tph	8-10 tph
Cotton Seed	400	1.5-2 tph	2-3 tph	3-5 tph
Linen Seed	700	3-5 tph	5-7 tph	8-10 tph

Please note that input and output quantities that can be obtained interdependent and also depend on the input contamination. The throughput capacities shown are also dependent on the input contamination and the required quality of output. Also another capacity element is if cleaner machine working alone or integrated to a cleaning plant.

SECTION VIEW

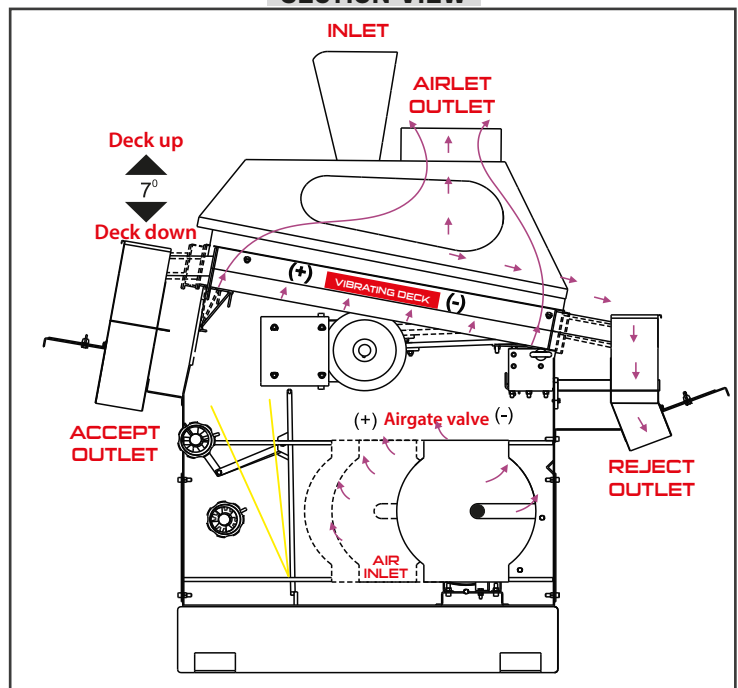

DE-STONER PRESSURE TYPE

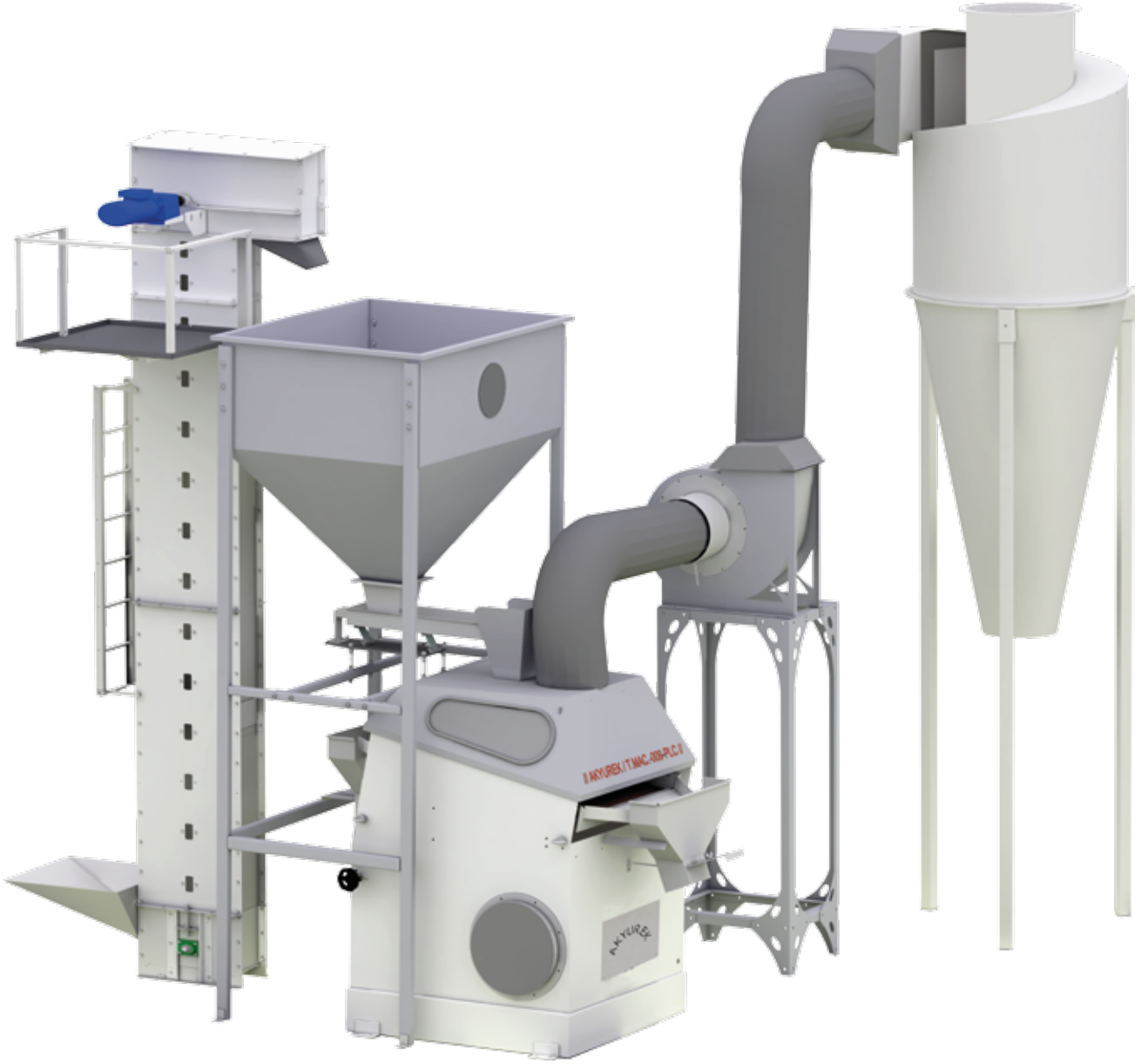

Akyürek Makine A.Ş.

Karaduvar Mahallesi 65117 Sokak
No:37 Mersin / TÜRKİYE

Telefon: +90 324 237 47 48 - +90 324 234 47 59
+90 324 237 37 14 - +90 324 237 47 10

Faks: +90 324 234 47 07

E-Posta: info@akyurekltd.com

Web: www.akyurekltd.com



Akyürek Makine A.Ş.

Karaduvar Avenue 65117 Street
No:37 Mersin / TÜRKİYE

Phone: +90 324 237 47 48 - +90 324 234 47 59
+90 324 237 37 14 - +90 324 237 47 10

Fax: +90 324 234 47 07

E-Mail: info@akyurekltd.com

Web: www.akyurekltd.com



ISO 9001 - 2008
QUALITY ASSURANCE

+90 444 6 259

www.akyurekltd.com

Akyürek Kardesler San.Tic.Ltd.Sti. Have all the copyrights of the Information and pictures provided in this catalogue. We have all rights to do necessary adjustments on the product & these changes may not reflect on the catalogue at the moment of production. We will do our utmost to inform you all the changes if and when.